

LWGY LIQUID TURBINE FLOW METER

Summary

LWGY series turbine flowmeter is a new generation flowmeter which has absorbed advanced international technology of flow instrumentation. After optimized design, it has the features of simple structure, light weight, high precision, good reproducibility, responsiveness, easy installation and maintenance, etc. Turbine flowmeter is a precision flow measurement instrument to measure the flow and total volume of liquid without impurities and corrosion. It is widely used in petroleum, chemical, metallurgical, scientific research and other fields.



Features

1. High accuracy: generally up to $\pm 1\%R$, $\pm 0.5\%R$, high precision type up to $\pm 0.2\%R$.
2. Good repeatability, with short-term repeatability of 0.05% R to 0.2%R, which makes it the preferred flow meter in trade settlements, precisely because of its good repeatability, such as frequent or on-line calibration for high accuracy.
3. Output pulse frequency signal, suitable for total volume measurement and computer connection, no zero drift, strong anti-interference ability.
4. Very high frequency signals (3-4 KHz) can be obtained, with strong signal separation rates.
5. Wide range, up to 1:20 for medium and large sizes and 1:10 for small sizes.
6. Compact and lightweight, easy to install and maintain, with high circulation capacity.
7. Suitable for high-pressure measurement, no holes are required on the meter body, and it is easy to make a high-pressure meter
8. There are many types of special sensors, which can be designed according to the special needs of users, such as low temperature type, two-way type, down hole type, special type for sand mixing;

9. It can be made into a plug-in type, suitable for large size measurement, with low pressure loss, low price, continuous flow out, easy installation and maintenance.

Operating Principle

When the measured liquid flows through the sensor type, under the action of the fluid, the blade rotates under force, and its speed is proportional to the average flow velocity of the pipeline. The rotation of the blade periodically changes the magnetic resistance value of the magnetic circuit, and the periodic change of the magnetic flux resistance in the detection coil generates an induced electromotive force with the same frequency as the blade rotation frequency, which is amplified, converted and processed.

Technical Parameters

1. Basic Parameters

Measured medium	No impurities, low viscosity, no strong corrosive liquid	
Executive standard	Turbine flow sensor (JB/T9246-1999)	
Inspection procedures	Turbine flow meter (JJG1037-2008)	
Instrument size (mm) and connection type	Flange connection type	DN15-DN200
	Thread connection type	DN4-DN50
	Flange clamping type	DN4-DN200
Accuracy	±1%R、±0.5%R、±0.2%R (Need to be customized)	
Range ability	1:10 ; 1:15 ; 1:20	
Sensor material	SS304, SS316 (L) etc	
Conditions of use	Medium temperature :-20°C ~	Ambient temperature: -20°C~+60°C

	+80°C		
	Relative humidity: 5%-90%	Atmospheric pressure: 86 Kpa ~ 106Kpa	
Signal output function	Pulse signal, 4~20mA signal		
Communication output	RS485 communication, HART protocol, etc.		
Power supply	A. External power supply: +24VDC±15%, ripple ≤±5%, suitable for 4-20mA output, pulse output, RS485, etc.		
	B. Internal power supply: 1 set of 3.6V lithium battery, the battery voltage can work normally at 3.0V~3.6V.		
Flange standard	Normal standard	GB/T9113-2000	
	Other standard	International	DIN, ANSI, JIS etc.
		China	HG, JB
Thread specification	Conventional specifications British pipe thread (male thread) (refer to standard GB/T7307-2001)		
	Other specifications: female thread, spherical thread, NPT thread, etc.		
Electrical Interface	M20*1.5 female thread (NPT thread needs to be customized)		
Explosion-proof	ExdIICT6Gb		
Ingress protection	IP65 or higher (can be customized)		

Note: Non-national standard flanges need to be customized; unconventional inch pipe threads need to be customized.

2. Measuring Range and Size

Liquid turbine flowmeter measuring range table

Instrument size (mm)	Normal flow range extended flow range		Conventional connection type and pressure rating	Special pressure rating (MPa)	Starting flow (m3/h)	Maximum pressure loss *1 (KPa)	
	(m3/h)	(m3/h)					
4	0.04~0.25	0.04-0.4	Threaded installation, 6.3 MPa	Clamping connection<42MPa	0.02	120	
6	0.1-0.6	0.06-0.6	Threaded installation,6.3 MPa		0.05	80	
10	0.2~1.2	0.15-1.5	Threaded installation,6.3 MPa		0.07	50	
15	0.6-6	0.5-5	Threaded installation,6.3 MPa		0.35	35	
20	0.8-8	0.45 ~ 9	Threaded installation,6.3 MPa		0.3	35	
25	1-10	0.5 ~ 10	Threaded installation,6.3MPa		0.4	35	
32	1.5-15	0.8-15	Threaded installation,6.3 MPa		0.6	35	
40	2-20	1~20	Threaded installation,6.3 MPa		0.6	35	
50	4~40	2~40	Flange installation, 4.0 MPa		Clamping connection <26MPa	1	35
65	7~70	5~70	Flange installation, 1.6MPa			4	25
80	10-100	7-100	Flange installation, 1.6MPa	5		25	
100	20 ~ 200	10-200	Flange installation, 1.6 MPa	Clamping connection <15MPa	8	25	
125	25-250	13-250	Flange installation, 1.6 MPa		10	25	
150	30-300	15-300	Flange installation, 1.6 MPa		12	25	
200	80 ~ 800	40 ~ 800	Flange installation, 1.6 Mpa	Clamping connection <11MPa	20	25	
Accuracy level*2	±0.5%	±1.0%	-	-	-	-	

Notes:

1. The maximum pressure loss is the pressure loss when the flowmeter works at the maximum flow point.
The medium is water, and the temperature is normal.
2. Products with an accuracy level of $\pm 0.2\%$ need to be customized, and the flow range is smaller than the conventional range.

Instrument Classification

1. According to the function of the instrument, the LWGY turbine flowmeter can be divided into 2 categories:

- ① Turbine flow sensor/transmitter
- ② Intelligent turbine flowmeter

2. Function description

① N/A Type Turbine Flow Sensor/Transmitter

- The N/A turbine flow sensor/transmitter does not have the local display function, and only transmits the flow signal. The flow signal can be divided into pulse signal or current signal (4-20mA);
- The instrument is low in price, high in integration, and small in size. It is especially suitable for the use of secondary display instrument, PLC, DCS and other computer control systems.
- According to different output signals, such products can be divided into pulse output type and 4-20mA output type
- Pulse output type: 12~24VDC power supply, three-wire pulse output, high voltage $\geq 8V$, low voltage $\leq 0.8V$; signal transmission distance ≤ 1000 meters; pulse= $1/2f*1000$ (ms);
- 4-20mA output type: 24VDC power supply, two-wire 4-20mA output, signal transmission distance ≤ 1000 meters.
- This kind of turbine flowmeter products are divided into two types: basic type and explosion-proof type (ExdIICT6 Gb).



LWGY-N Type



LWGY-A Type

② Intelligent G/E Liquid Turbine Flowmeter

Intelligent liquid turbine flowmeter is a new type of multifunctional and integrated intelligent instrument, with local indicator, and can also output the flow signal. The series of products using segment code LCD display, high contrast, low power consumption, two display units can be selected. A variety of electrical signal output mode can be selected, working conditions equivalent pulse can be set in a variety of output modes, especially suitable for quantitative control to use. This series of products can not only display the common volume flow rate unit, but also through the setting of the measured medium density, display the mass flow rate unit. On the basis of the above functions, in order to meet the different needs, the user can choose to use the MODBUS protocol based on the RS485 interface communication function.

Power supply	DC220V DC24V 3.6V lithium battery
Pulse output	Load capacity >1100Ω, High level amplitude >22V, Low level amplitude <0.8V, Pulse width 1/2fin*1000(ms)
Current output	Load capacity 900, two-wire or three-wire 4-20mA, 0-20mA output are optional
Communication interface	RS485 interface using MODBUS-RTU protocol, HART



LWGY-G Type



LWGY-E Type

Model Selection Table

Model										Contents
LWGY-	□	/□	/□	/□	/□	/□	/□	/□	/□	
Instrument type	N									24V power supply, no local display, pulse output type
	A									24V power supply, local display, 4~20 mA output type
	G1									Battery power supply, local display, no output
	GX									External power supply, local display, RS485/current/pulse output
	E1									Battery power supply, local display, no output
	EX									External power supply, local display, RS485/current/pulse output
Connection type	FL									Flange connection
	LW									Thread connection
	JZ									Clamping connection
Size	4									DN4
	6									DN6
	10									DN10
	15									DN15
	20									DN20
	52									DN25
	32									DN32
	40									DN40
	50									DN50
	65									DN65
	80									DN80
	100									DN100
	125									DN125
150									DN150	
200									DN200	
Accuracy				05						±0.5%

	10					±1.0%
	02					±0.2 (negotiate before, long production cycle)
Measuring range	S					Standard range
	W					Extended range
	Z					Special range
Body material	S					SS304
	L					SS316 (L)
Blade material	S					2Cr13 blade
	L					Duplex steel blade
Explosion-proof	N					No
	E					ExdIICT6 Gb
Pressure & temperature rating	N					Conventional
	H(X)					High pressure reference table 4-2

Installation Size

1. Threaded Connection Type Size

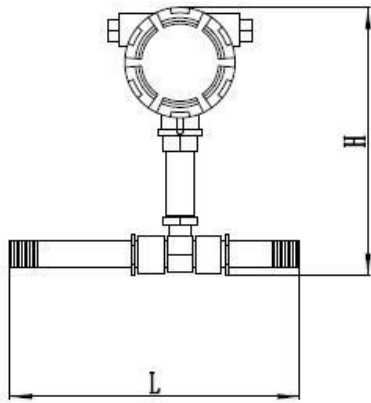

**DN4~DN10 Threaded Connection Sensor
(Include Straight Pipe)**

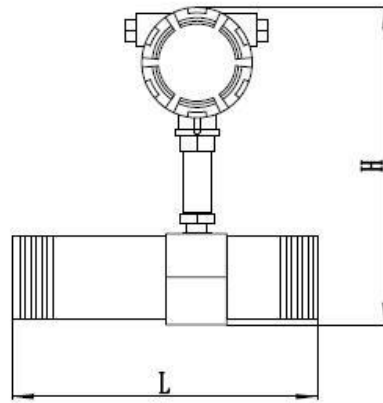

**DN15~DN50 Threaded Connection Sensor
(Include Straight Pipe)**

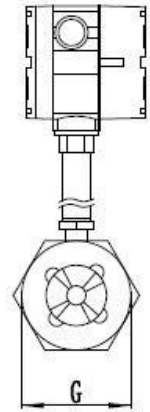

Threaded Connection Diagram

Threaded Connection Size Comparison Chart

	L* (mm)	H (mm)				G (male thread)
		Pulse Type	Explosion-proof pulse type	4-20mA output type	Intelligent display type	
4	225	140	145	145	210	G1/2
6	225	140	145	145	210	G1/2
10	345	145	150	145	210	G1/2
15	75	145	150	150	215	G1
20	80	150	155	155	220	G1
25	100	155	160	160	225	G1 1/4
32	140	175	180	180	245	G2
40	140	180	185	180	250	G2
50	150	185	190	190	255	G2 1/2

Note: The above DN4-DN10 flow sensor contains the factory standard straight pipe section size;
 DN15-DN50 flow sensor does not contain straight pipe section size.

2. Flange Connection Type Size

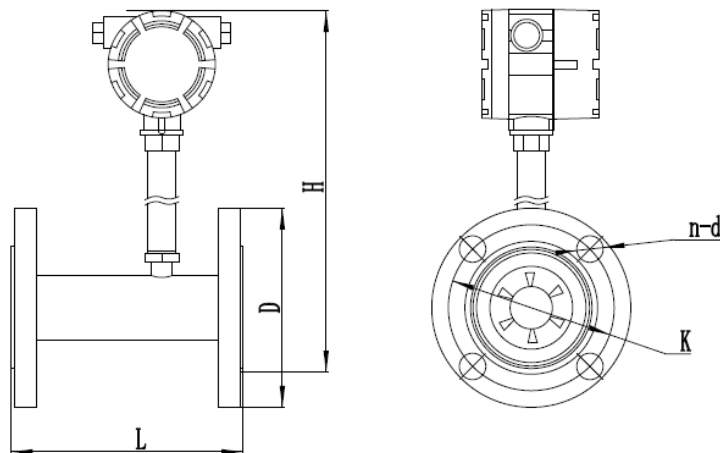

Flange Connection Diagram

Flange Connection Size Comparison Chart

Instrument size(mm)	L* (mm)	D (mm)	K (mm)	H (mm)				d (mm)	n (number of holes)	Standard Pressure Rating
				Pulse output type	Explosion-proof pulse output type	4-20mA output type	Intelligent display type			
15	75	95	65	175	180	180	245	14	4	2.5MPa
20	80	105	75	185	190	190	255	14	4	
25	100	115	85	200	195	195	260	14	4	
32	140	140	100	210	215	215	275	18	4	
40	140	150	110	195	220	220	285	18	4	
50	150	165	125	230	235	235	295	18	4	
65	170	185	145	255	260	260	325	18	8	1.6MPa
80	200	200	160	260	265	265	330	18	8	
100	220	220	180	285	285	285	350	18	8	
125	250	250	210	310	315	315	380	18	8	
150	300	285	240	345	345	345	410	22	8	
200	350	340	295	395	400	400	465	22	12	

Note: The above DN4-DN10 flow sensor contains the factory standard straight pipe section size;
 DN15-DN50 flow sensor does not contain straight pipe section size.

3. Clamping Connection Type Size

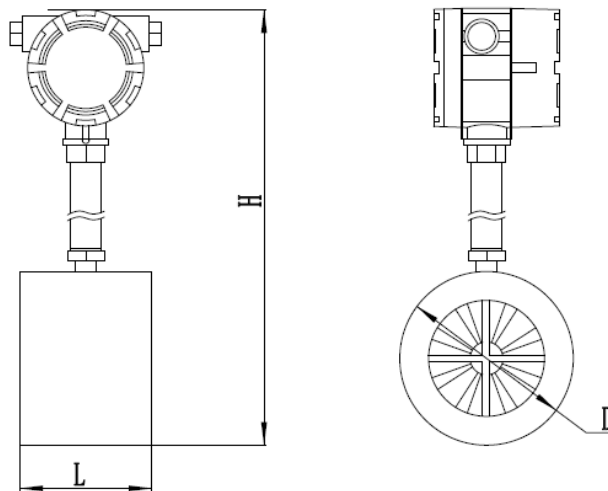

Clamping Connection Diagram

Clamping Connection Size Comparison Chart

Instrument size (mm)	L* D		H (mm)			Intelligent display type
	(mm)	(mm)	Pulse output type	Explosion-proof pulse output type	4-20mA output type	
4	50	38	145	X		215
6	50	38	145		215	
10	50	38	145		215	
15	55	47	155		220	
20	60	54	160		225	
25	60	57	165		230	
32	70	66	170		240	
40	70	72	180		245	
50	70	92	195		260	
65	80	100	205		210	210
80	90	112	220	225	225	290
100	100	137	245	250	250	310
125	120	165	270	275	275	340
150	150	190	295	300	300	365
200	150	243	350	350	350	415

Flow Meter Installation Notes

1. Installation Location

The pipe must be completely filled with liquid. It is important to keep the pipe completely filled with liquid at all times, otherwise the flow rate display will be affected, which may cause measurement errors.

Avoid bubbles. If bubbles enter the measuring tube, the flow rate display may be affected, which may cause measurement errors.

2. Installation Site and Requirements

- ① The sensor should be installed in a place that is convenient for maintenance, and the pipeline is free from vibration, strong electromagnetic interference and thermal radiation.

The horizontal installation of the sensor requires that the pipeline should not have a visually perceptible tilt (usually within 5°), and the vertical deviation of the pipeline for the vertical installation of the sensor should also be less than 5°. In places where the flow cannot be stopped, a bypass pipe and a reliable shut-off valve should be installed, and the bypass pipe must be leak-free during measurement.

Connect a short pipe to replace the sensor at the position where the sensor is installed in the newly laid pipeline. After the "line purge" is completed and the pipeline is confirmed to be cleaned, the sensor is formally connected.

If the fluid contains impurities, a filter should be installed on the upstream side of the sensor, and the pipeline should be regularly cleaned and drained of sediment impurities; if the measured fluid contains gas, an aerator should be installed on the upstream side of the sensor. The drainage and degassing ports of the filter and degasser should be directed to a safe place.

When the sensor is installed outdoors, there should be measures to avoid direct sunlight and prevent rain.

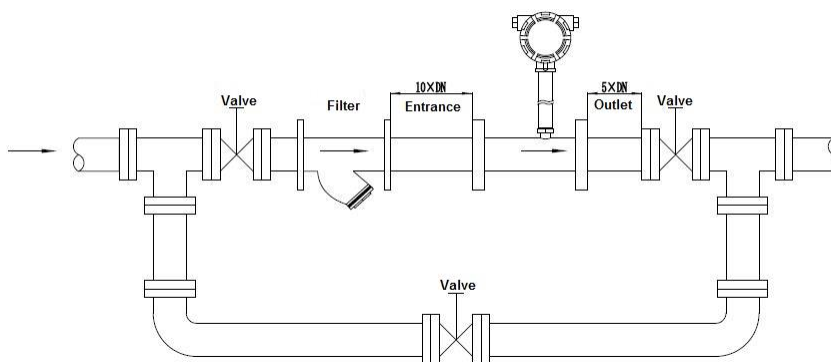

3. Required Upstream and Downstream Straight Pipe Length

The turbine flowmeter is sensitive to distortions in the distribution of flow velocity in the pipe and rotating flow, the entry into the sensor should be fully developed turbulence, therefore, according to the upstream

side of the sensor flow stopper type of necessary straight pipe section or rectifier, the length of the inlet section and outlet section straight pipe section.

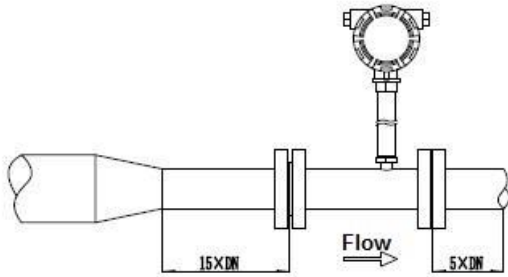

(1) Concentrically retracted fully open valve

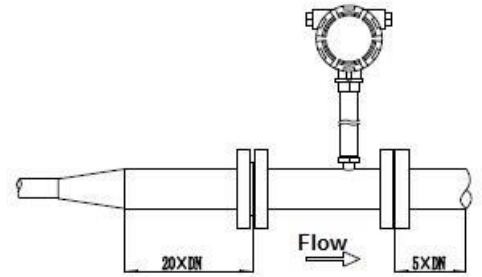

(2) Concentric pipe expansion fully open valve

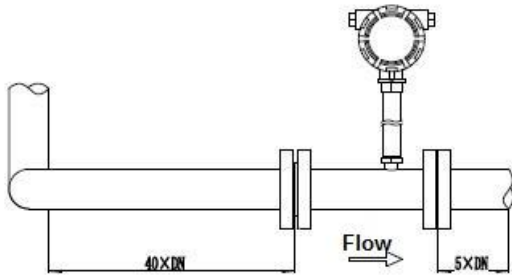

(3) Two 90° elbows in different planes

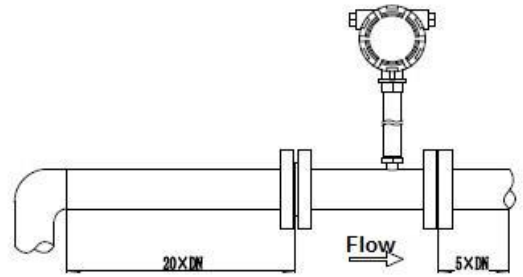

(4) One 90° elbow

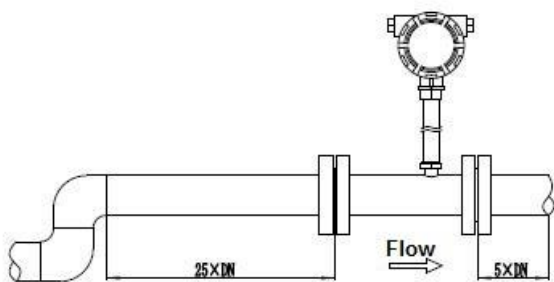

(5) Two 90° elbows on the same plane

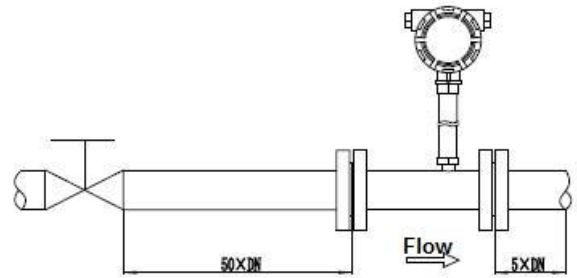

(6) Regulating valve half-open valve

Figure 8-4: Upstream and downstream straight pipe requirements

Ordering Information

Users in the order, please read this selection sample, and for the fluid medium and field requirements, select

a suitable flow meter, and then provide the following information to the manufacturer.

- Liquid turbine flow meter models.
- The name of the fluid medium and its physical parameters.
- Maximum working pressure, maximum working temperature, and minimum working temperature at which the fluid will operate.
- The common flow rate, maximum flow rate, and minimum flow rate of the fluid.