



ZTD | WITH DLC 3100 LEVEL CONTROLLER

DISPLACER LEVEL TRANSMITTER

ZTD Displacer Level Transmitter

with DLC3100 Level Controller

Operation Manual

ZTD - DT - JS - 1036 - 2020
v1



Preface

Thank you for choosing the products of Dandong Top Electronics Instrument (Group)Co.,Ltd.

This operation manual provides you with important information on installation, connection and commissioning as well as on maintenance, troubleshooting and storage. Please read it carefully before installation and commissioning and keep it as part of the product near the meter for easy reading.

This manual can be downloaded by entering the version number at www.ddtop.com .

If the instructions are not followed, the protection provided by the meter may be destroyed.

Trademark, Copyright and Restriction Instructions

Dandong Top Electronics Instrument (Group) Co.,Ltd.®, Dandong Top Pump Co., Ltd.®, DDTOP® are registered trademarks of the company.

The performance specifications of the meter are effective as of the date of publication and are subject to change without notice. Dandong Top Electronics Instrument (Group)Co.,Ltd. reserves the right to modify the products described in this manual at any time without prior notice.

Quality Assurance

Dandong Top Electronics Instrument (Group) Co.,Ltd. guarantees that all glass plate level gauge have no defects in materials and manufacturing processes within one year from the date of delivery.

During the warranty period, if the product returns with quality problems and the claim is determined by the manufacturer to be within the scope of warranty, Dandong Top Electronics Instrument (Group) Co.,Ltd. is responsible for repair or replacement of the buyer (or owner) free of charge.

Dandong Top Electronics Instrument (Group) Co.,Ltd. is not responsible for the costs caused by improper use of equipment, labor claims, direct or subsequent damage and installation and use of equipment. In addition to the special written warranty certificate for certain products of Dandong Top Electronics Instrument (Group) Co.,Ltd., Dandong Top Electronics Instrument (Group) Co.,Ltd. does not provide any express or implied warranty.

Quality

Dandong Top Electronics Instrument (Group) Co.,Ltd. has passed the ISO9001 quality system certification. The whole process of product production is strictly in accordance with the scope of the quality system, providing the strongest guarantee for product and service quality.

CONTENTS

1 Safety Tips	4
1.1 Explosion may result in death or serious injury.....	4
1.2 Process leaks can cause serious injury or death.....	4
1.3 Failure to follow safe installation guidelines may result in death or serious injury.....	4
2 Product Manual	4
2.1 Main Structure of Product	4
2.2 Operating Principle	5
2.3 Packing	5
2.4 Hoisting and Transporting.....	5
2.5 Warehousing	5
3 Technical Characteristics.....	5
3.1 Main Performance	5
3.2 Main Parameters.....	5
4 Dimensional Schematic.....	6
5 Unpacking and Inspection	7
5.1 Unpacking Inspection Notice.....	7
5.2 Check Content	8
6 Installation	8
6.1 Installation Tool	8
6.2 Installation Requirements	8
6.3 Installation Operation Process.....	9
7 Debugging	11
7.1 Preparation for Commissioning.....	11
7.2 Electrical Wiring.....	11
7.3 Debugging Operation Process.....	13
8 Precautions.....	14
9 Failure Analysis and Elimination.....	14
10 Disassembly.....	16
10.1 Warning.....	16
10.2 Waste Removal	16
11 Product Certification.....	16

1 Safety Tips

It is expressly prohibited to modify or change products for safety reasons, repair or replacement only allows the use of accessories specified by the manufacturer.

1.1 Explosion may result in death or serious injury.

When installing equipment in an explosive atmosphere, be sure to follow applicable local, national, international standards, codes, and procedures. Be sure to install the equipment in Intrinsically safe or non-flammable site operating procedures.

1.2 Process leaks can cause serious injury or death.

Care should be taken to lift the transmitter. If the process seal is damaged, the medium may leak at the joint.

1.3 Failure to follow safe installation guidelines may result in death or serious injury.

The operations described in this manual are performed by professionally trained and qualified professionals or end-user specialized professionals to complete.

2 Product Manual

2.1 Main Structure of Product-Figure 1

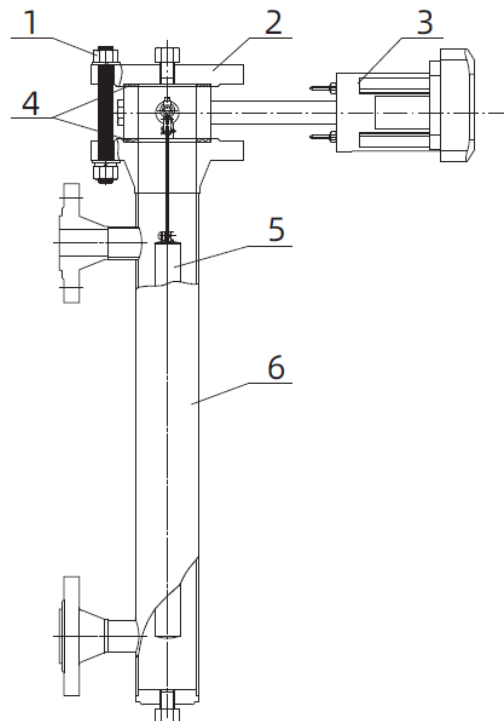

Figure 1 Product Structure

1. Fasteners, including bolt and nut washers
2. Flange cover, can be equipped with venting parts according to user requirements
3. Transmitter, 360° rotation, 8 viewing positions
4. Seal, two pieces
5. Displacer, buoyancy measuring element
6. Chamber

2.2 Operating Principle

The change of the level of the measured medium causes the buoyancy of the inner cylinder to change, and the change is transmitted to the torque tube assembly, so that the torque tube rotates at an angle with the mandrel. A sensing system coupled to the torsion spool produces a voltage signal. The level controller electronic component measures the level signal and provides a 4-20 mA current output. The microcontroller measures the ambient temperature to compensate for changes in liquid density due to process temperature changes. The LCD displays information such as analog output, process variables, process temperature (RTD required), torque tube rotation angle, and percentage of level positions.

2.3 Packing

Please send the packaging waste to a special recycling agency.

2.4 Hoisting and Transporting

Please select qualified hoisting equipment and lifting straps, and pay attention to safety.

2.5 Warehousing

Storage temperature -20°C~40°C; storage humidity ≤ 40%

3 Technical Characteristics

3.1 Main Performance

3.1.1

Certification mark: Intrinsically safe type Ex ia II CT5/T6 Ga

Explosion-proof type Ex d II C T5/T6 Gb

3.1.2 Product executive standards

GB/T13969 Float Type Level Meter

Q/AMM 013 Float Level Transmitter.

3.2 Main Parameters

3.2.1 Power supply: 12~30V DC; reverse polarity protection in the controller (controller voltage ≥ 17.75 V DC when HART protocol communication).

3.2.2 Output signal: 4 ~ 20mA DC.

4 Dimensional Schematic -Figure 2

If the order is required to be a special size, the actual size will prevail.

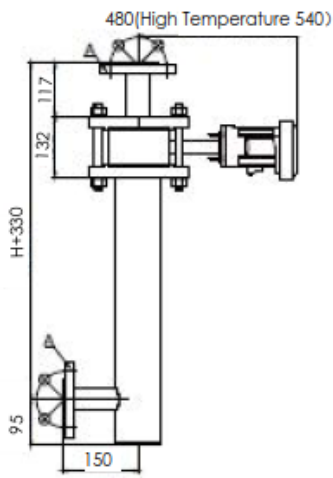

A Top-side Mounted

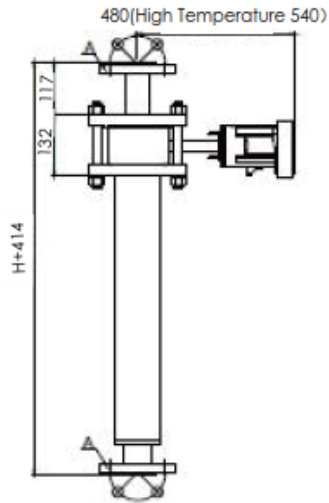

B Top-bottom Mounted

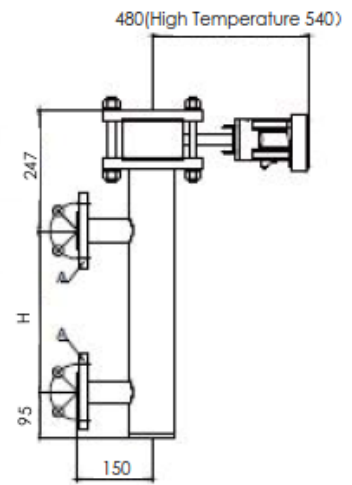

C Side-side Mounted

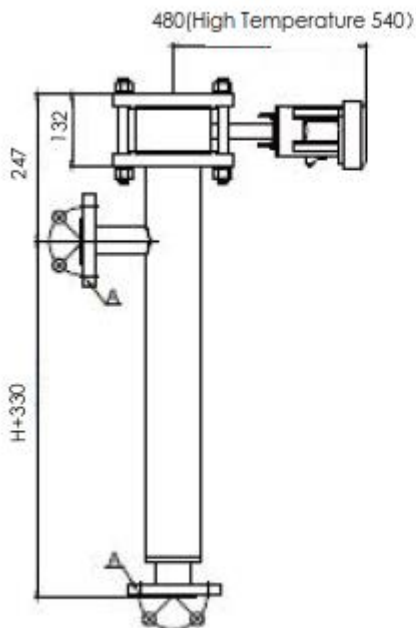

D Side-bottom Mounted

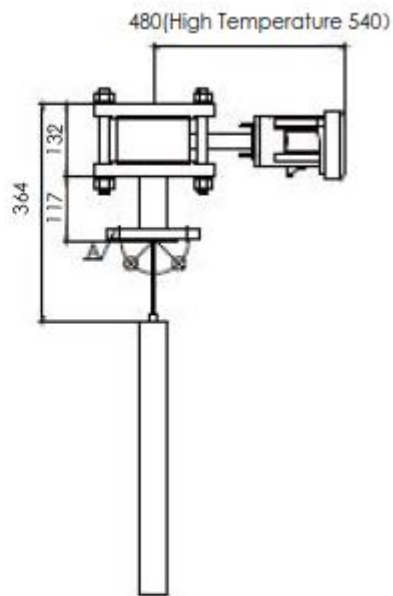

E Top Mounted

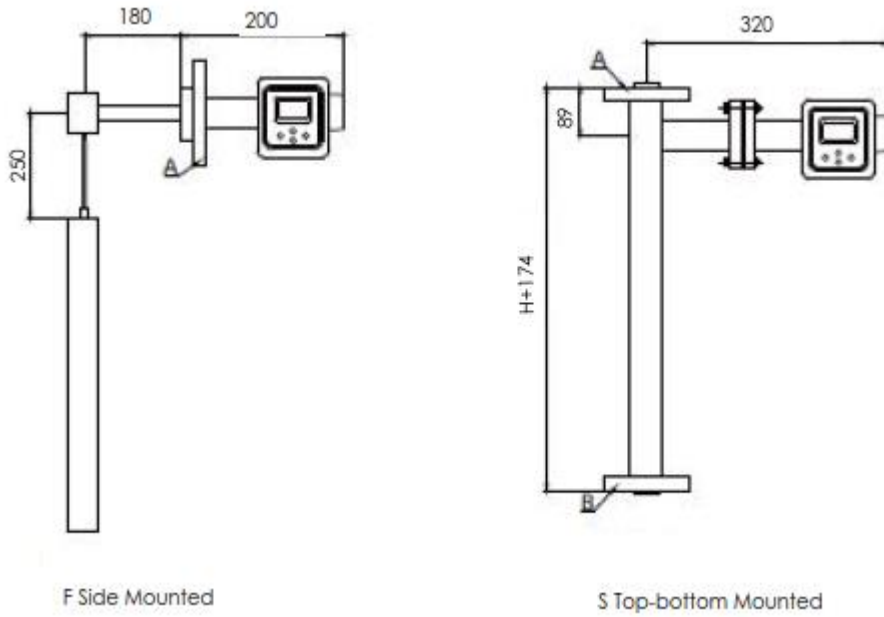



Figure 2 Dimensional Schematic

5 Unpacking and Inspection

5.1 Unpacking Inspection Notice

5.1.1 Check whether the product nameplate (Figure 3) is consistent with the supply list information.



Displacer Level Transmitter
Model: _____

Nominal Pressure		Design Temperature	≤	°C
Range	mm	Float Diameter	Φ	mm
Float Weight	Kg	Output Signal	(4~20) mA+Hart	
Light Medium Density		g/m ³	<input checked="" type="checkbox"/>	Ex ia II CT5 / T6 Ga
Heavy Medium Density		g/m ³	<input checked="" type="checkbox"/>	Ex d II CT5 / T6 Gb
Accuracy		IP66	Tag No.	
Date / Number of Manufacture		/		

Figure 3 Product Nameplate

5.1.2 According to the packing list, check the quantity of each part and the material is correct.

5.2 Check Content

5.2.1 Check the appearance of the instrument for defects, damage and other abnormal conditions.

5.2.2 If the ZTD transmitter and other parts are packaged separately, before installing the inner cylinder, please remove the two damping rubber rings on the inner cylinder (Figure 4).

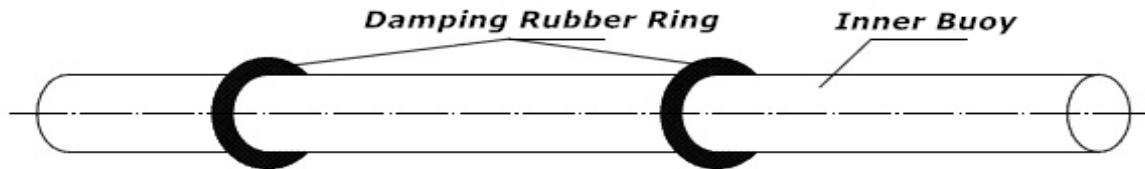

Figure 4 Damping Rubber Ring

6 Installation

6.1 Installation Tool

6.1.1 Wrenches, flange gaskets and flange bolts for process connections.

6.1.2 Level

6.2 Installation Requirements

6.2.1 When installing the measuring chamber, the axis of the outer cylinder side flange must be perpendicular to the horizontal plane (Figure 5). If the ZTD transmitter and the remaining parts are packaged separately, install the parts according to the position shown in Figure 1. If it has been installed as a whole, follow 6.3.5.

6.2.2 Transmitter and inner cylinder installation: Use the connector pull ring on the inner cylinder (Figure 5), insert the connector into the top of the transmitter lever, and then turn the pull ring to the locked position. Locked on the lever (Figure 6)



Figure 5



Figure 6

6.3 Installation Operation Process - Figure 7

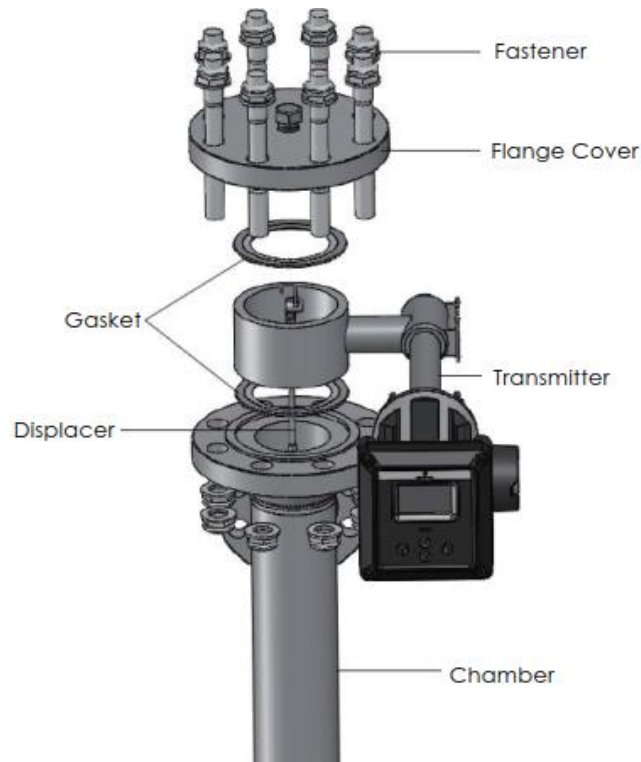

Figure 7 Installation

6.3.1 Remove the bolt and nut connecting the flange cover and the outer cylinder, take out the sealing gasket, and place one gasket on the upper flange sealing surface of the outer cylinder (Figure 7-1);

6.3.2 Connect the inner cylinder and the transmitter according to 6.2.2 and put it into the outer cylinder. Ensure that the ring flange of the transmitter is in good contact with the gasket (Figure 7-2);



Figure 7-1

Figure 7-2

6.3.3 Place the other gasket on the flange cover sealing surface and install the flange cover on the transmitter ring flange. Ensure that the transmitter ring flange is in good contact with the gasket. Align the flange bolt holes (Figure 7-2).

6.3.4 Install the bolts and nuts that connect the flange cover to the outer cylinder and alternately tighten the nuts (Figure 7-3).

6.3.5 Install the outer cylinder side flange on the device, and ensure that the flange and the gasket are in good contact (Figure 7-4).

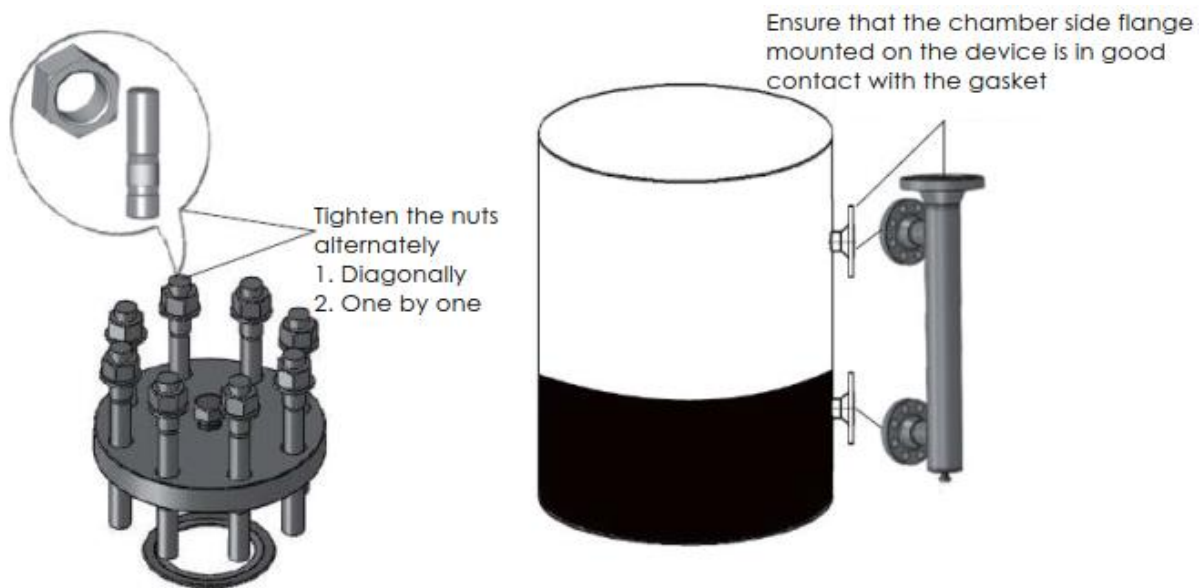

Figure 7-3

Figure 7-4

7 Debugging

7.1 Preparation for Commissioning

7.1.1 Debugging Tool

- 1) Power supply
- 2) 230Ω-600Ω resistors for HART communication protocol
- 3) Handheld supporting HART protocol (Rosemount 475)

7.1.2 Slider Lock

Before adjusting the DLC3100 level controller, press and hold the arrow position slider and slide it in the direction of the arrow to the other end, and the slider enters the positioning slot to lock (Figure 8).



Figure 8

7.2 Electrical Wiring

7.2.1 Unscrew the power terminal box cover (Figure 9) and connect the current signal lines (Figure 10). Where T is the test terminal; + is connected to the positive pole of the power supply, - is connected to the negative pole of the power supply; R1, R2 is connected to the PT100 (temperature sensor, if any); the internal grounding wire is connected to the outer casing of the armored cable (if any).



Figure 9

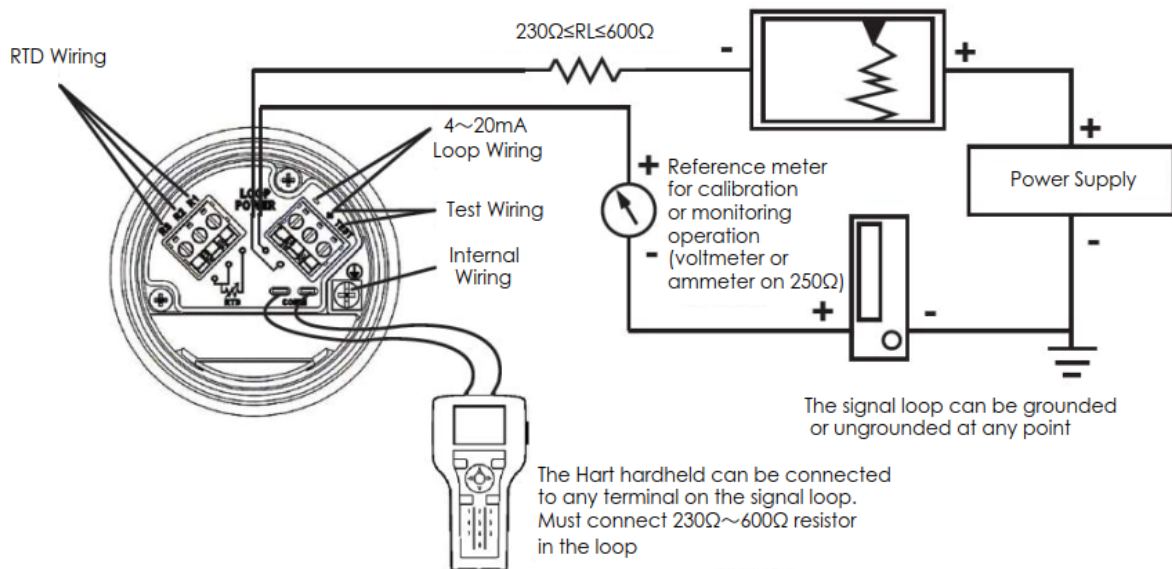

Figure 10

7.2.2 After the wiring is completed, check the polarity of the wiring correctly. The instrument case must be well grounded, and then the 24VDC standard power supply is turned on.

7.2.3 When communicating with HART protocol, the power supply voltage of the intelligent liquid level controller must be ≥ 17.75 VDC. If it is lower than this voltage, the configuration information will be considered incorrect.

7.2.4 A resistance of 230 Ω ~600 Ω must be connected in the loop to communicate with the HART communicator.

7.2.5 It is recommended to use the handheld device supporting the HART475 communication

7.3 Debugging Operation Process

7.3.1 Precautions before Commissioning

- 1) The instrument should not be subjected to strong vibration and shock, especially for the lever with the inner cylinder, and should not be pulled hard to avoid damage to the torque tube.
- 2) The instrument shall not participate in impactful process tests such as air sweeps performed before the device is put into production.

7.3.2 During commissioning, if water is used as the medium (non-measured medium), the following two conditions will occur:

$\rho_{\text{medium}} < \rho_{\text{water}}$ and $\rho_{\text{medium}} > \rho_{\text{water}}$. But regardless of the density of the medium, you can pass the formula:

$h_{\text{Water injection height}} = \rho_{\text{medium}} \cdot H_{\text{full scale height}} / \rho_{\text{water}}$ Calculate the corresponding water injection height and the corresponding output current value.

※The meter has been calibrated before leaving the factory.

7.3.3 Adjusting the on-site LCD Display Value (Taking HART475 Ver3.7 as an Example)

Under normal circumstances, if the user does not change the physical parameters of the media provided by the user at the beginning of use,

Follow these steps:

Two-point calibration method: Hang the inner cylinder on the lever, operate the hand manipulator, and enter the HART. 2 (Online) → 2 (Configure) → 5 (Calibration) → 1 (Calibration) → 2 (Two Point) → 1 (PV Units) In this interface, adjust the liquid level to the zero point and enter the liquid level value. 0.0, click ENTER → 1 (Confirm) Click ENTER → adjust the level to 100% in this screen, enter the level value (example 800mm), click ENTER → 1 (Confirm) Click ENTER → setting is complete (Figure 11, switch between menus by pressing the right button of the handheld device).

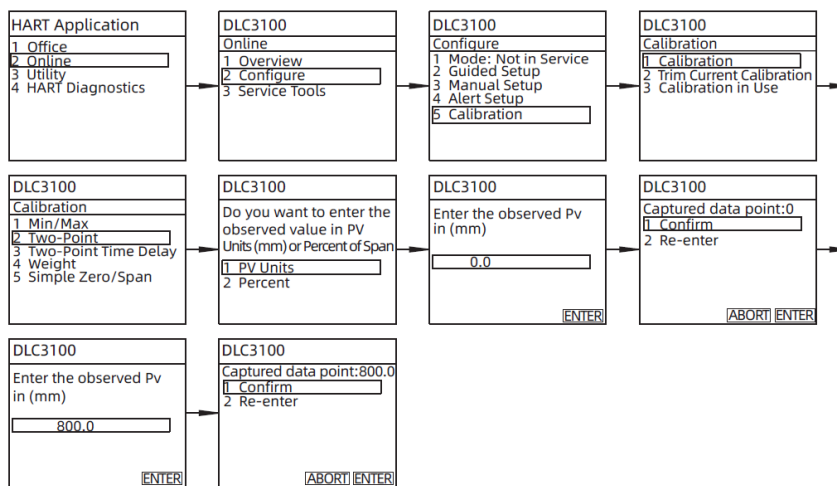

Figure 11

After completing the above operation, the level transmitter can be used.

※ Pay special attention to the unity of the measurement unit when setting.

8 Precautions

8.1 The density of use should be the same as the design density. If the density changes, the parameters need to be changed again to calibrate the instrument

8.2 During the disassembly and assembly process, the torsion tube should be protected as much as possible to prevent damage to the force;

8.3 Make sure the power supply is safe and reliable, and the power supply should be connected according to the correct positive and negative poles;

8.4 Do not operate the instrument with an unsupported handheld device;

8.5 When the vibration is large, it is not suitable to use the displacer level transmitter;

8.6 Medium with viscosity $\geq 500\text{mPa/s}$ is not suitable for measurement with a displacer level transmitter;

8.7 The operating temperature range of electronic components is $-40\text{ }^{\circ}\text{C} \sim +80\text{ }^{\circ}\text{C}$, the temperature range displayed on the LCD screen is $-30\text{ }^{\circ}\text{C} \sim +80\text{ }^{\circ}\text{C}$ (out of range LCD display, remote transmission is normal);

8.8 After the commissioning, tighten the display and power cover to prevent the instrument from getting wet.

9 Failure Analysis and Elimination

Phenomenon	Reason	Solution
After power-on, the LCD has no display, no signal output	1. The power supply polarity is reversed or the power supply is faulty; 2. There is an open circuit in the line.	1. Check if the power supply voltage is normal, and check if the power supply circuit has an open circuit; 2. If there is a safety barrier in the circuit, check if the safety barrier is working properly; 3. Connect the positive and negative power supplies correctly.

<p>The actual level of the device changes, and the meter indication and output do not change with the level, or the variation range is inconsistent.</p>	<ol style="list-style-type: none"> 1. The inner cylinder anti-vibration rubber ring is not removed, and friction occurs with the outer cylinder wall; 2. The inner cylinder or lever is caught by the foreign object; 3. The outer cylinder is installed without vertical friction with the inner cylinder; 4. The inner tube connector is reversed, and the inner tube is rubbed against the outer tube wall; 5. The locking device of the transmitter is not pushed to the unlocked position. 	<ol style="list-style-type: none"> 1. In the process of transportation, in order to prevent collision damage of the inner and outer cylinders, the inner cylinder will be installed with anti-vibration rubber ring when the factory is shipped, and the rubber ring should be taken out during the installation process; 2. Check if there is any foreign matter in the inner cylinder and the lever, and remove the foreign matter; 3. Correct the outer cylinder to be perpendicular to the ground; 4. Re-install the inner cylinder correctly; 5. Push the locking device to the unlocked position. (in the direction of the arrow)
<p>The meter displays the output maximum or over range, and there is no change in the commissioning, and there is no change in the field indication.</p>	<ol style="list-style-type: none"> 1. The inner cylinder is detached; 2. The instrument junction box is faulty; 3. The locking device of the transmitter is not pushed to the unlocked position. 	<ol style="list-style-type: none"> 1. Connect the inner tube 2. Replace the junction box 3. Push the locking device to the unlock position
<p>After the meter is calibrated, it is put into use and there is a deviation from the actual level value. The indication is not allowed.</p>	<ol style="list-style-type: none"> 1. The process parameters are not accurate (the actual density is inconsistent with the design density); 2. On-site heating causes the density of the medium to change; 3. Local indication level indicator is not accurate. 	<ol style="list-style-type: none"> 1. Re-determine the process parameters, recalibrate the meter at the new density, or modify the meter display and output using the fixed-point migration function. 2. Adjust the temperature of the heating to prevent the density of the measured medium from changing; 3. Check the local level gauge to determine its accurate reflection of the actual level.
<p>Tuning instrument is not linear, and has a large difference.</p>	<ol style="list-style-type: none"> 1. The inner tube is stuck by debris, and the range cannot be opened. 2. The inner cylinder anti-vibration rubber ring is not removed. 3. The power supply voltage is abnormal. 4. Parameter calculation error during verification 5. The locking device of the transmitter is not pushed to the unlock position. 	<ol style="list-style-type: none"> 1. Remove debris 2. Take out the rubber ring 3. Adjust the power supply voltage 4. Recalculate the correct parameters. 5. Push the locking device to the unlock position
<p>The header shows garbled characters and the output signal does not change.</p>	<ol style="list-style-type: none"> 1. The circuit board is faulty; 2. The power supply voltage is abnormal. 	<ol style="list-style-type: none"> 1. Replace the meter head; 2. Detect the power supply replacement barrier.

When the meter is adjusted, the output current of the meter is high or low.	<ol style="list-style-type: none"> 1. Power failure; 2. The meter insulation is not good. 	<ol style="list-style-type: none"> 1. Check the power supply and replace the safety barrier; 2. Detect the insulation of the meter terminals. If there is any problem with the insulation, replace the meter head.
The LCD display percentage and level value do not match the actual output current value.	<ol style="list-style-type: none"> 1. URV and LRV input errors; 2. The instrument is not calibrated with a regular handheld device, resulting in a digital signal that does not match the analog signal. 	<ol style="list-style-type: none"> 1. Re-enter the URV and LRV values (URV=range; LRV=zero). 2. Calibrate the current using the handheld Modulo Calibration function.
The meter displays 0%; the level changes and the meter output do not change.	<ol style="list-style-type: none"> 1. The meter parameter density value becomes "0"; 2. Instrument parameter torque tube stiffness is "0"; 3. The locking device of the transmitter is not pushed to the unlock position; 4. The inner cylinder is detached or the anti-vibration rubber ring is not taken out. 	<ol style="list-style-type: none"> 1. Re-enter the correct density value; 2. Re-enter the torque tube stiffness value 8-30, and re-calibrate the instrument at two points; 3. Push the locking device to the unlocked position; 4. Reinstall the inner cylinder or remove the anti-vibration rubber ring.
The meter output continues to decrease and cannot be properly calibrated.	<ol style="list-style-type: none"> 1. Torque tube failure; 2. The inner cylinder is smashed, leaked, and fed into the medium. 	<ol style="list-style-type: none"> 1. Replace the torque tube; 2. Replace the inner buoy
The handheld device is not communicating.	<ol style="list-style-type: none"> 1. Check the model and version of the Communicator. 2. Check if there is a problem with the power supply. 	<ol style="list-style-type: none"> 1. Use a handheld device that supports the HART protocol (Rosemount 275, 375, 475); 2. Replace the power supply; 3. Change the safety barrier, or string 250 ohm resistor.

10 Disassembly

10.1 Warning





Attention should be paid to hazardous process conditions, such as pressure inside the vessel, high temperatures, corrosive or toxic media, etc.

Refer to the instructions in section 6.3 Installation Operation and Section 7.2 Electrical Wiring to remove the parts in the reverse order of operation.

10.2 Waste Removal

Waste disposal should be carried out in accordance with the current guidelines in each region.

11 Product Certification

Product Certification		
Certification	Certification Number	Scope of Certification/Description
HART Communication Protocol 		HART website https://fieldcommgroup.org/about Enter the product number to search
FM U.S. Explosion-proof rating Certification 	ID 3008498	XP:CL I , DIV 1,GP ABCD, T5 NI:CL I , DIV 2,GP ABCD, T5 DIP:CL II , DIV 1,GP EFG,T5 S:CL II ,DIV 2, GP FG IS:CL I , II , III DIV 1, GP PER DWG 28B57445, T5
Canadian North American Dual Accredited CSA Certification 	1088348 (016426_0_000)	CL I , DIV1, GP BCD, T6 CL I , DIV2, GP ABCD,T6 CL II ,DIV1,2, GP E, F, G Ex ia INTRANSICALLY SAFE CL I , II , III DIV1, GP PER DWG28B5744, T6
Explosion-proof Certifications 	Intrinsically safe GYJ15.1098X Explosion Isolation GYJ15.1096X	Ex ia II CT5 Ga Ex d II CT5 / T6 Gb
Formal Approval Certification for Measuring Instruments 	10F212-21	

12. Annex: DLC3100 Key Operation Menu

1. The main interface when powered on is as follows

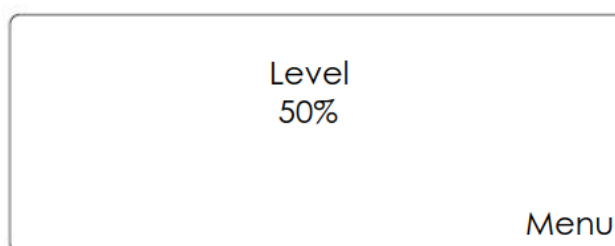

The middle position is off the current measurement type, the level shows the level, and the interface shows the interface.

The middle position displays the current level value, including engineering units, percentage, and current output values.

On the bottom right menu bar, use the "→ key" to enter the menu and configure the parameters.

The lower left corner of the screen displays the current alarm information, and if an alarm occurs, a blinking alarm will appear.

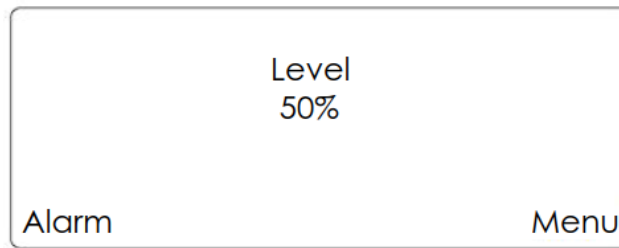

2. Key operations

The LCD panel has four keys, namely "↑", "↓", "←" and "→" keys. Keystrokes. The duration of a keystroke operation divides the keys into short and long presses.

Short press: A short press is a press and release of a button for less than 3 seconds. Short presses are available for all four "↑", "↓", "←" and "→" keys.

Press and hold: Press and hold means to press, hold, or release the button action for more than 3 seconds. A long press is only available for the "←" and "→" keys.

3. Key menus

In normal display, press the "→" key" briefly and enter the menu.

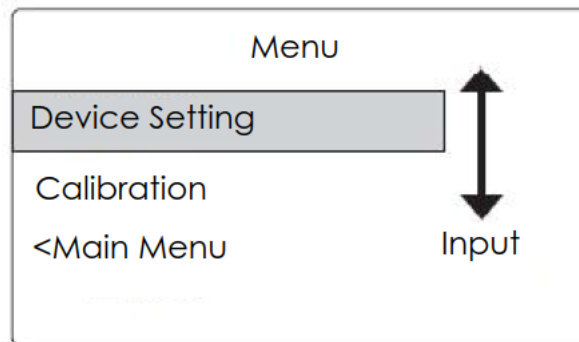

The following menu can be set from the main menu by pressing the "↑" or "↓".

Menu Option	<ul style="list-style-type: none"> ● Device Setting ● Calibration ● Level Compensation ● Scope Setting ● Density Setting ● Alarm Setting ● Use Compulsorily ● Protection ● Setting Review ● Measure LCD Display ● HART Setting ● Language
Main Menu	Back to the main screen
Input	Select the currently selected menu and enter the sub-menu

3.1 Instrument Settings Menu

Select the "Instrument Settings" menu and press the "→" to enter the following left interface.

In this screen, press and hold the "→" for 3S and then release the key to enter the middle screen as shown below, the screen will be briefly displayed and the unit will be selected directly.

Menu (screen on the right below).

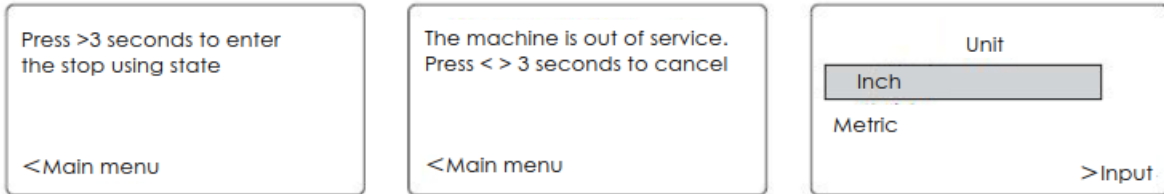

Press the "↑" and "↓" to toggle between metric and inches, press the input key to select the current unit and enter the menu, select "Metric" unit and enter the float length setting menu.



Below there are "Press > Enter" and "Press < Return" cycles.

- Press and hold the "←" for 3 seconds to release and return to the 3.1 Unit Setting menu.
- Press "→" and "←" to toggle the bit to set the value, and "↑" and "↓" to toggle the size of the value.
- Press and hold the "→" for 3S to release and enter the float volume submenu.



Below there are "Press > Enter" and "Press < Return" cycles.

Press and hold the "←" for 3S to release and return to the float length setting menu.

- Press "→" and "←" to toggle the bit to set the value, and "↑" and "↓" to toggle the size of the value.
- Press and hold the "→" for 3S to release and enter the float weight submenu.

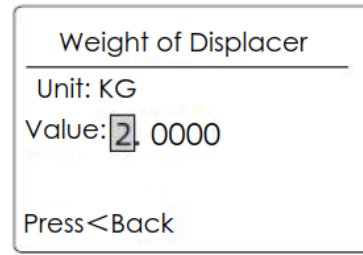
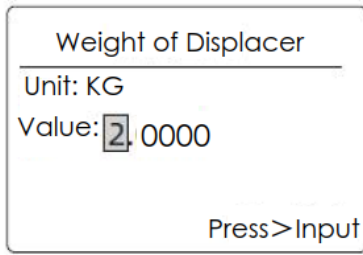

Below there are "Press > Enter" and "Press < Return" cycles.

- Press and hold the "← key" for 3S to release and return to the float volume setting menu.
- Press "→" and "←" to toggle the bit to set the value, and "↑" and "↓" to toggle the size of the value.
- Press and hold the "→" for 3S to release and enter the lever length submenu.

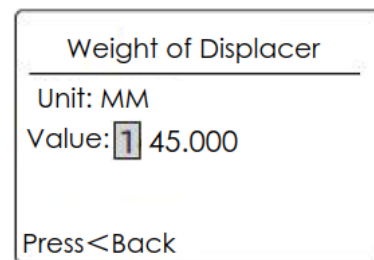
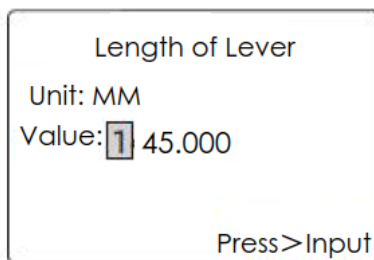

Below there are "Press > Enter" and "Press < Return" cycles.

- Press and hold the "← key" for 3S to release and return to the float weight setting menu.
- Press "→" and "←" to toggle the bit to set the value, and "↑" and "↓" to toggle the size of the value.
- Press and hold the "→" for 3 seconds to release and enter the installation method submenu.

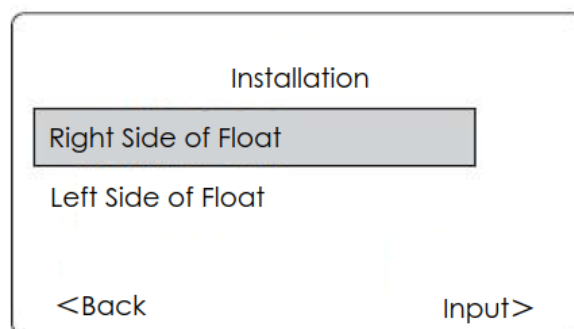

The following two options are "Enter >" and "< Return".

- Press the "←" to return to the lever length setting menu.
- Press "↑" and "↓" to toggle between the two options.
- Press "→" to enter the torque tube material selection menu.

Torque Tube Material

K-MONEL

INCONEL

<Back Input>

The following two options are "Enter >" and "< Return".

- Press the "←" to return to the installation setting menu.
- Press "↑" and "↓" to toggle between multiple material options.
- Press the "→" briefly to confirm the selection and 249 type selection menu.

249 Type

249

249B / 249BP

<Back Input>

The following two options are "Enter >" and "< Return".

- Press the "←" to return to the torque tube material setting menu.
- Press "↑" and "↓" to toggle between multiple material options, the default is "Other".
- Press the "→" key briefly to confirm the selection and enter the torque tube wall selection menu.

Torque Tube Wall

Thin

Standard

<Back Input>

The following two options are "Enter >" and "< Return".

- Press the "←" to return to the 249 type setting menu.
- Press "↑" and "↓" to toggle between multiple material options, the default is "Other".
- Press the "→" to confirm the selection and enter the application selection menu.

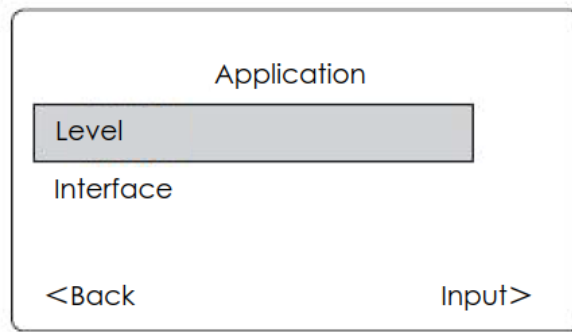

The following two options are "Enter >" and "< Return".

- Press the "←" to return to the torque tube wall setting menu.
- Press "↑" and "↓" to toggle between multiple material options, the default is "Other".
- Press the "→" to confirm the selection and enter the application selection menu.

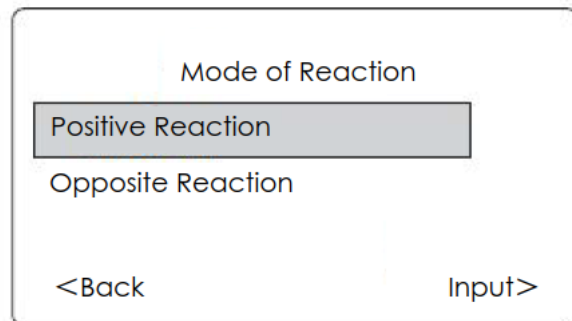

The following two options are "Enter >" and "< Return".

- Press the "←" to return to the application settings menu.
- Press "↑" and "↓" to toggle between multiple material options, the default is "Other".
- Press the "→" to confirm the selection and enter the application selection menu.

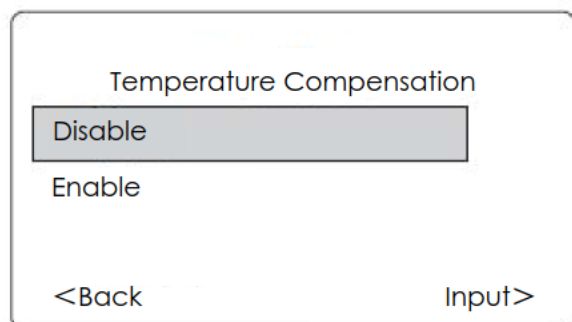

The following two options are "Enter >" and "< Return".

- Press the "←" to return to the method settings menu.
- Press "↑" and "↓" to toggle between multiple material options, the default is "Other".
- Press the "→" to confirm the selection and enter the density input menu.

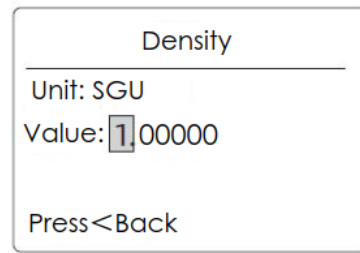
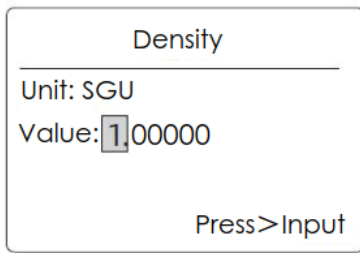

Below there are "Press > Enter" and "Press < Return" cycles.

- Press and hold the "←" for 3S to release and return to the temperature compensation setting menu.
- Press the "→" and "←" briefly to change the bit of the setting value, and press the "↑" and "↓" briefly to change the size of the value.
- Press and hold the "→" for 3S to release and return to the main menu.

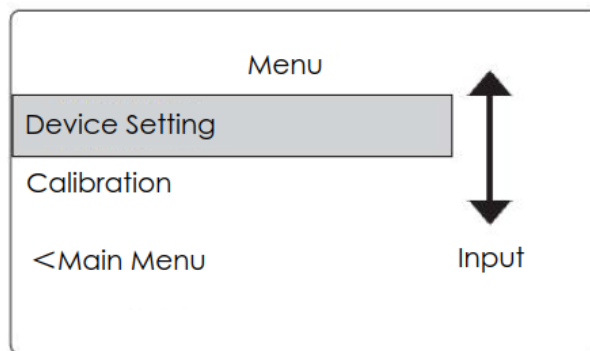

3.2 Checking the Menu

Select "Verify" menu, press "→" to enter the left side interface below.

In this screen, press and hold the "→ key" for 3S and release the key to enter the following middle interface, and then enter the verification menu directly after a short display. (Screen on the right below)

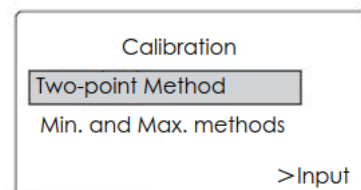
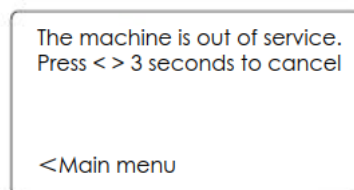
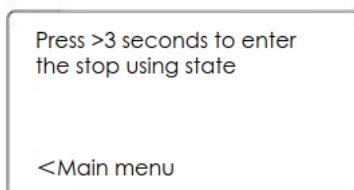

Pressing the "↑" or "↓" after the calibration has been passed will select the following calibration menu.

Calibration	<ul style="list-style-type: none"> ● Two-point Method ● Min. / Max. Method ● Two-point Delay Method ● Weight Method ● Zero Point / Range Method ● Modified Zero Position ● Modified Gain ● Torque Tube Rate
Input	Select the currently selected menu and enter the corresponding operation method interface

3.2.1 Two-point Calibration

- Press the "↑" or "↓" to select the two-point calibration menu.
- Press the "→" briefly

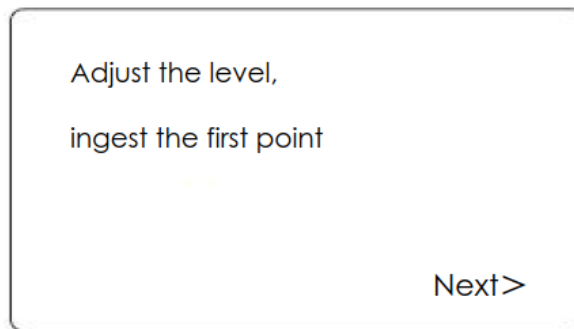

Adjust the liquid level to the zero point. Press the "→" briefly.

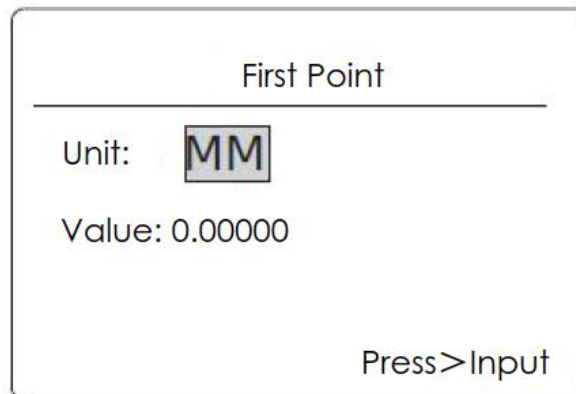

- Press the "↑" or "↓" to switch the unit between mm and %
- Press the "→" briefly to set the level of the first point.

First Point

Unit: MM

Value: 0.00000

Press>Input

- Press "→" and "←" to toggle the bit to set the value, and "↑" and "↓" to toggle the size of the value.
- 长按"→"键3S 释放后进入第二点设置菜单
- Press and hold the "→" for 3S to release and enter the second point setting menu.

Adjust the level,
ingest the second point

Next>

Adjust the liquid level to the zero point. Press the "→" briefly.

Second Point

Unit: MM

Value: 1100.00

Press>Input

- Press the "↑" or "↓" to switch the unit between mm and %.
- Press the "→" briefly to set the second point level.

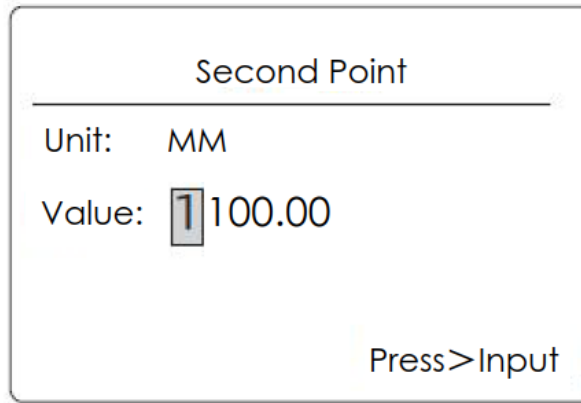

- Press the "→" and "←" briefly to change the bit of the setting value, and press the "↑" and "↓" keys briefly to change the size of the value.
- Press and hold the "→" for 3S to release the key and return to the main menu.

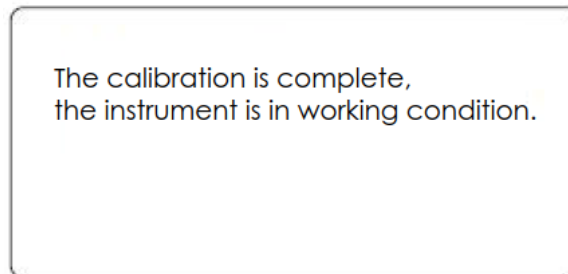

3.2.2 Min/Max Calibration

Press the "→" briefly to enter the menu.

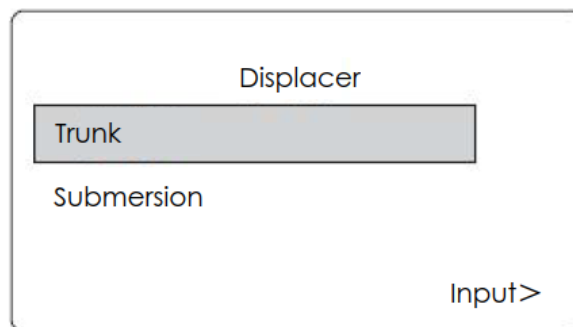

- Press the "↑" or "↓" briefly to move between the dry and submerged units, with the dry position indicating that the float is completely outside the liquid and the submerged position indicating that the float is completely submerged in the liquid.
- Select "Dry Level" and press the "→" to enter the zero calibration screen.

Displacer dry, stable, and point ingested

Next>

Press "→" briefly to confirm and enter the full-point calibration menu.

Displacer completely submerged,
stabilized, and ingested.

Next>

Press "→" briefly to confirm, the instrument calibration is completed and return to the main menu.

The calibration is complete,
the instrument is in working condition.

3.2.3 Two-point Delay Method Calibration

This is used for calibrations where the liquid level cannot be changed immediately.

Press the "→" briefly to enter the menu.

Did not finish the first point?

Yes

No

Input>

If this is the first point of calibration, select No and press the "→" briefly.

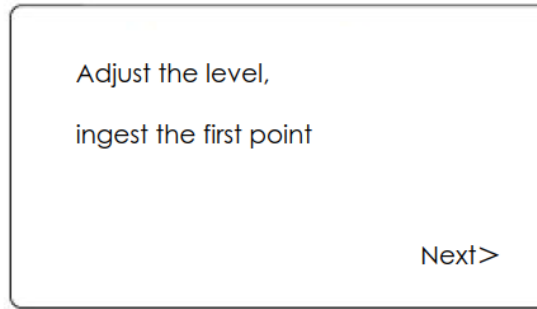

Adjust the liquid level to the zero point. Press the "→" briefly.

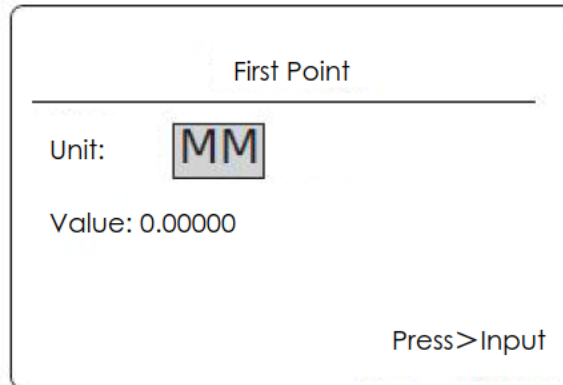

- Press the "↑" or "↓" to switch the unit between mm and %.
- Press the "→" briefly to set the level of the first point.
- Press and hold the "→" for 3S. After release, the first point calibration is completed and returns to the main menu.

Press the "→" briefly to enter the menu.

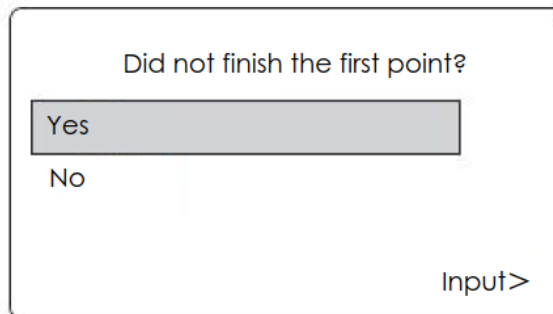

For the second point of calibration, select Yes and press the "→" briefly.

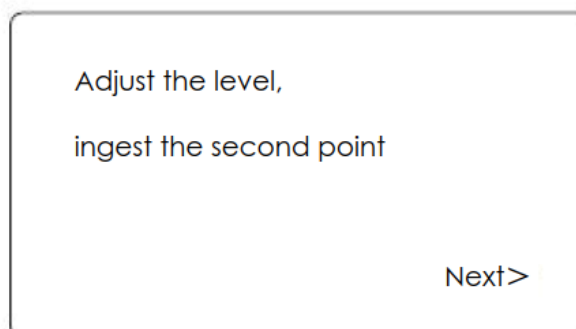

Adjust the liquid level to the zero point. Press the "→" briefly.

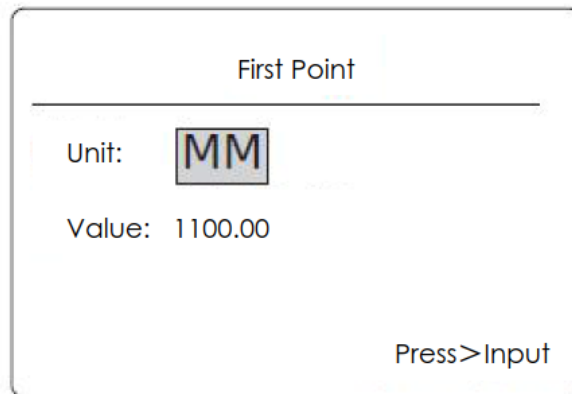

- Press the "↑" or "↓" to switch the unit between mm and %.
- Press the "→" briefly to set the second point level.

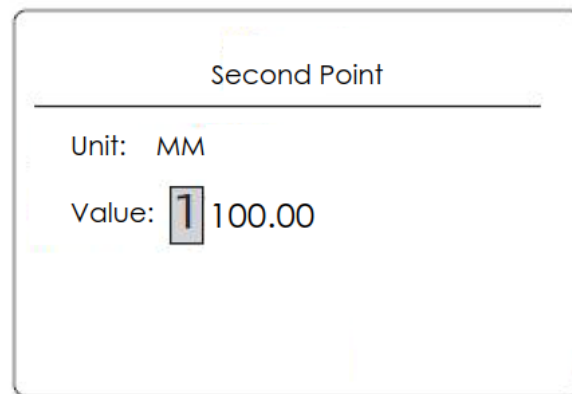

- Press the "→" and "←" briefly to change the bit of the setting value, and press the "↑" and "↓" briefly to change the size of the value.
- Press and hold the "→" for 3S to release the key and return to the main menu.

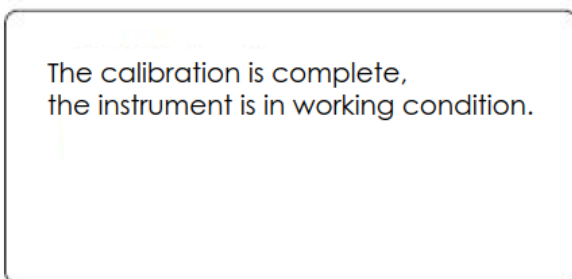

3.2.4 Gravimetric Calibration

Calibration by weight is not recommended.

3.2.5 Zero Point/Range Method

Consistent with 3.2.2 Min/Max calibration operation.

3.2.6 Correction of the Zero Position

Adjust the current zero value, zero migration, and fullness value unchanged.

3.2.7 Correct Gain

Adjust the current fullness measurement and zero night follows the fullness value.

3.2.8 Torque Tube Rate

Correction of the torque tube stiffness coefficient is not recommended.

3.3 Liquid Level Compensation Menu

Select the "Level Compensation" menu and press the "→" to enter the following interface.

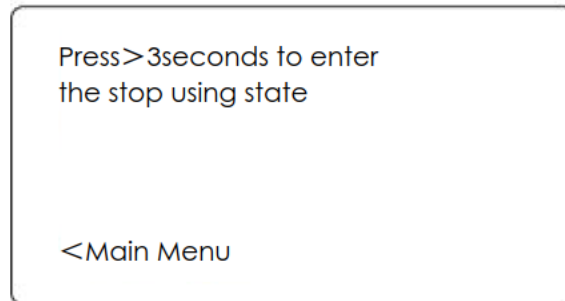

In this screen, press and hold the "→" for 3S and release the key to enter the following screen

After a brief display, you will go directly to the verify menu.

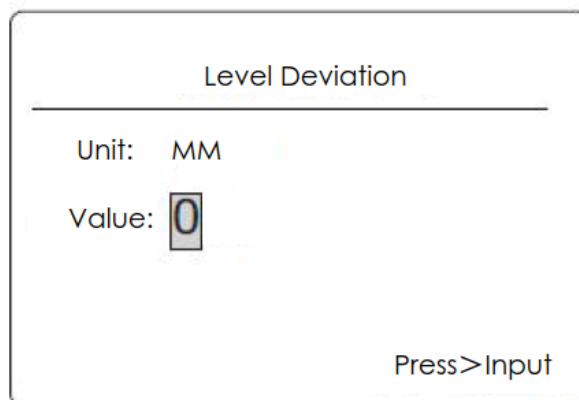

- Press the "→" and "←" briefly to toggle the bit for setting the value, and press the "↑" and "↓" keys briefly to enter the size of the value.
- Press and hold the "→" for 3S to release the key and enter the completion of input.

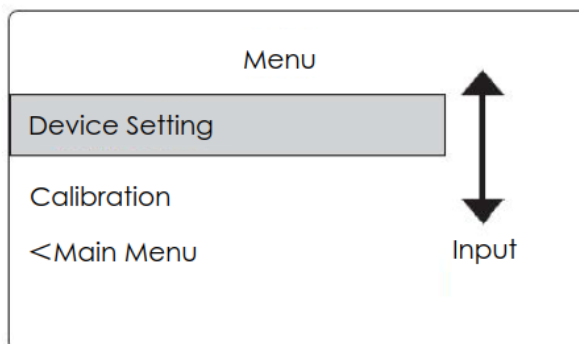

3.4 Range Setting Menu

Select the "Range Setting" menu and press the "→" to enter the following interface.

Press>3seconds to enter
the stop using state

<Main Menu

In this screen, press and hold the "→" for 3S to release the key and enter the following screen.

The machine is out of service,
press<>3 seconds to cancel

<Main Menu

Go directly to the low range input menu after a short display.

Lower Range

Unit: MM

Value: 0.00000

Press>Input

- Press the "→" and "←" briefly to change the bit for setting a value, and press the "↑" and "↓" keys briefly to enter the size of the value.
- Press and hold the "→" for 3S to release the key and enter the completion of inputting.

Higher Range

Unit: MM

Value: 1 100.00

Press>Input

- Press the "→" and "←" briefly to toggle the bit for setting the value, and press the "↑" and "↓" keys briefly to enter the size of the value.

briefly to enter the size of the value.

- Press and hold the "→" for 3S. When the key is released, inputting is completed, and the menu returns to the main menu.

3.5 Density Setting Menu

Select the "Density Settings" menu, and then press the "→" to enter the following interface.

In this screen, press and hold the "→" for 3S and release the key to enter the density input menu.

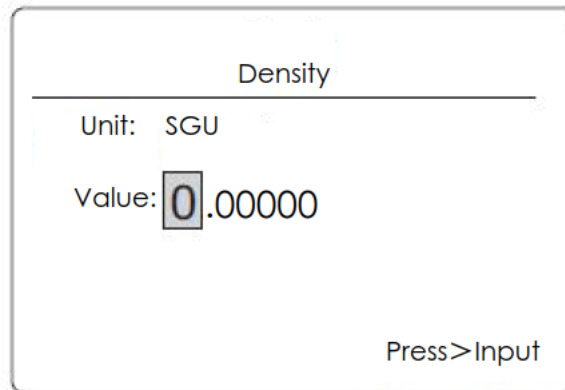

- Press the "→" and "←" briefly to toggle the bit for setting the value, and press the "↑" and "↓" briefly to enter the size of the value.
- Press and hold the "→" for 3S. When the key is released, inputting is completed, and the menu returns to the main menu.

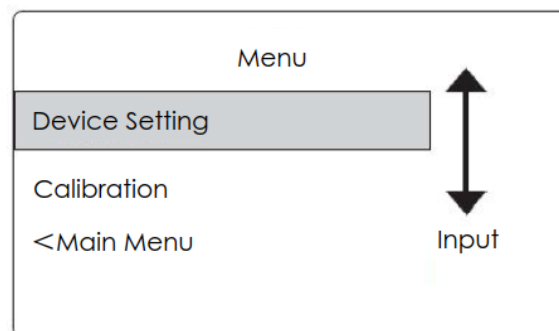

3.6 Alarm Settings Menu

Verify by pressing the "↑" or "↓" briefly to select the alarm setup menu.

Alarm Settings	<ul style="list-style-type: none"> ● Process Variable High ● Process Variable High High ● Process Variable Low ● Process Variable Low Low ● Process High Temperature Alarm ● Process Low Temperature Alarm ● Instrument High Temperature Alarm ● Instrument Low Temperature Alarm ● Complete
Input	Select the currently selected menu and enter the corresponding operation method interface

These menu operations are similar, and the following process variable high settings are used to illustrate the configuration process.

3.6.1 Process Variable High Setting

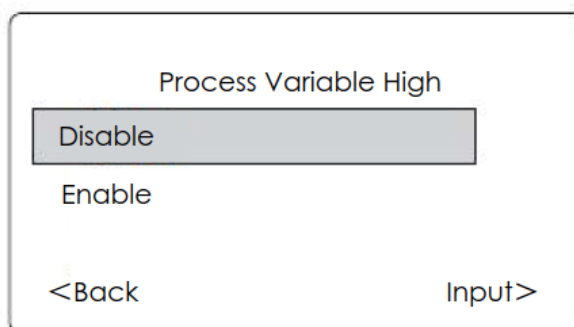

Press "→" to select process variable high level and enter process variable high level setting menu, select enable to enter alarm point setting menu.

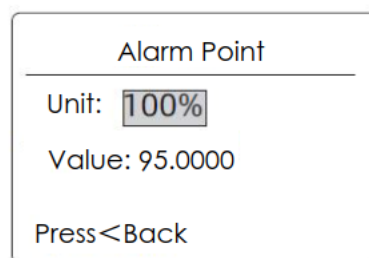
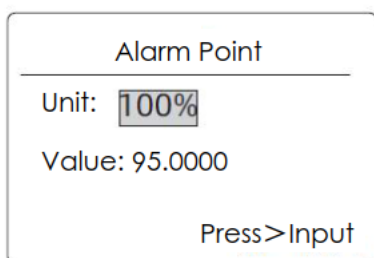

- Press the "↑" or "↓" briefly to switch the unit between mm and %.
- Press the "→" briefly to set the alarm value menu.

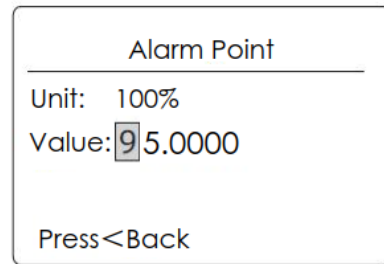
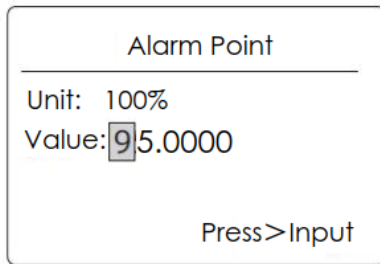

- Press the "→" and "←" briefly to toggle the bit to set the value, and press the "↑" and "↓" briefly to enter the size of the value.
- Press and hold the "→" for 3 seconds to release the key and return to the alarm menu.
- In the alarm menu, press the "↑" and "↓" briefly to complete the selection and return to the alarm setting menu.

3.7 Mandatory Use of Menu

The purpose of this menu is to allow the table to continue working in the event of some problem, or to eliminate the alarm for artificial use. Press the "→" briefly.

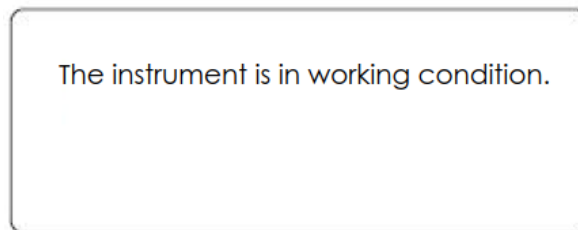

The instrument returns to the main menu and measures the level normally.

3.8 Protection Menu

The purpose of this menu is to protect the menu and prevent personnel from operating it.

Short press the "→"

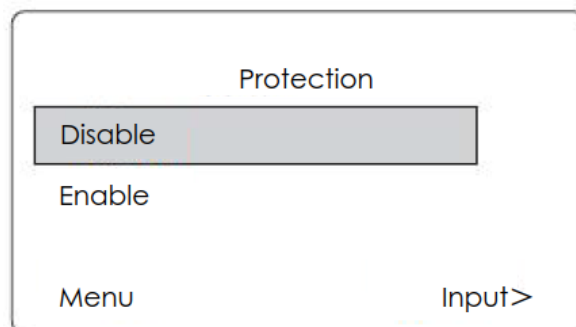

- Press "↑" and "↓" briefly to select whether to enable or disable the menu protection.
- Press the "→" briefly to confirm your selection and return to the main menu.

3.9 Setting the Review Menu

This menu is used to view the menu that you have just performed an operation on.

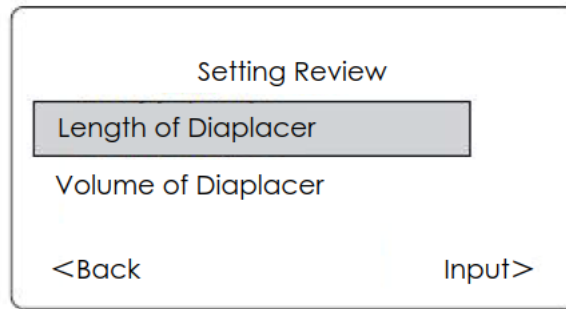

- 短按“↑键”和“↓键”可以查看您要查看的选项。
- Press the "↑" and "↓" briefly to view the options you want to view.
- 短按“→键”进入查看。
- Press the "→" to view the options.
- 短按“←键”返回主菜单。
- Press the "←" key to return to the main menu.

3.10 Measure LCD Monitor Menu

This menu is used to test the monitor for problems. You can test the monitor to see if it is fully lit and fully off.

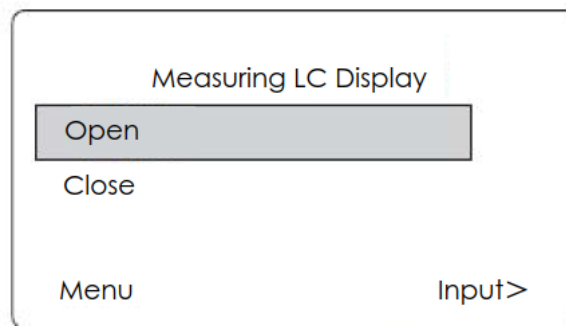

- Press the "↑" and "↓" briefly to view the options you want to view.
- Press the "→" to view the options.
- Press "←" to return to the main menu.

3.11 HART Setting Menu

This menu is used to set the HART version.

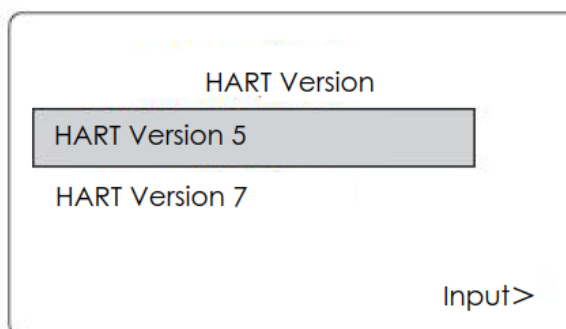

- Press "↑" and "↓" briefly to view the options you want to view.
- Press the "→" to select.
- Press "←" to return to the main menu.

3.12 Language Setting Menu

This menu serves to set the menu language.



- Press "↑" and "↓" briefly to view the options you want to view.
- Press the "→" to select.
- Press "←" to return to the main menu.